

SAM PuttLab Extended Reports											
Project		Session									
Name:	SPELARE	Name:	Extended Measurement								
Description:	TESTNING	Description:									
		Date:	02.07.2014								
Player		File									
Name:	Gornik, Tim	Name:	Extended Measurement								
Born:	1991	Description:									
Hand:	right	Date:	02.07.2014								
Handicap:	+2	Putts:	10								
Playing since:	-										
<table border="1"> <thead> <tr> <th>Tendency</th> <th>Timing</th> <th>Consistency</th> <th>Overall Rating</th> </tr> </thead> <tbody> <tr> <td>85.3%</td> <td>74.5%</td> <td>93.5%</td> <td>86.7%</td> </tr> </tbody> </table>				Tendency	Timing	Consistency	Overall Rating	85.3%	74.5%	93.5%	86.7%
Tendency	Timing	Consistency	Overall Rating								
85.3%	74.5%	93.5%	86.7%								

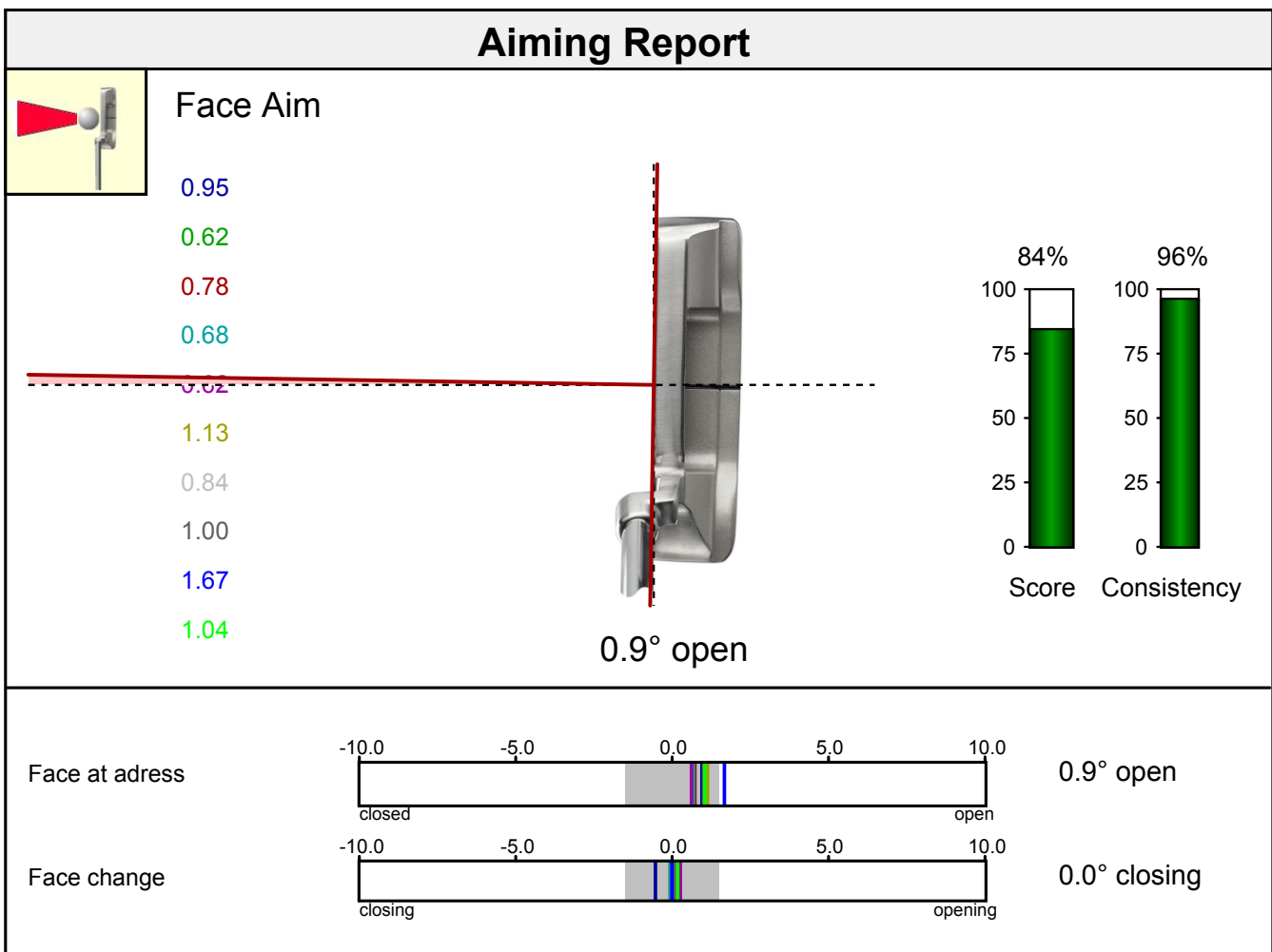

Project: SPELARE
 Player: Gornik, Tim
 File: Extended Measurement
 Date: 02.07.2014

Direction

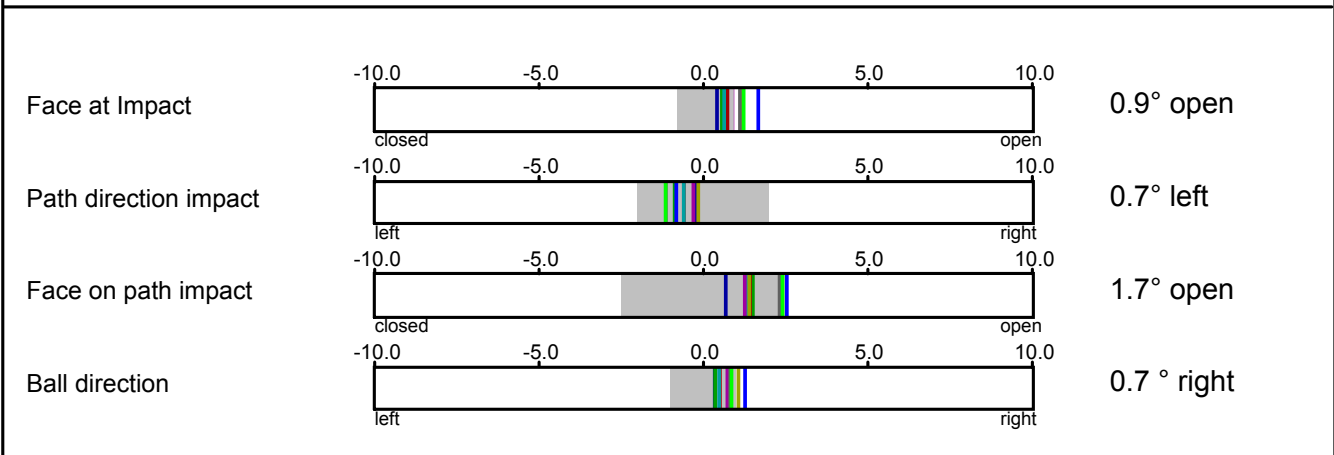
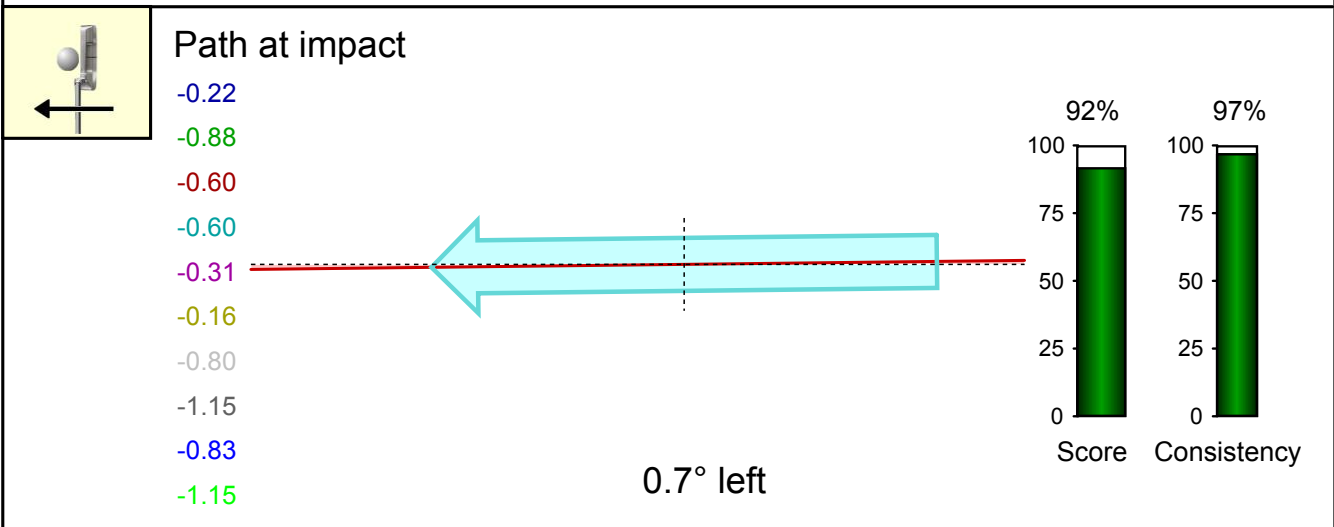
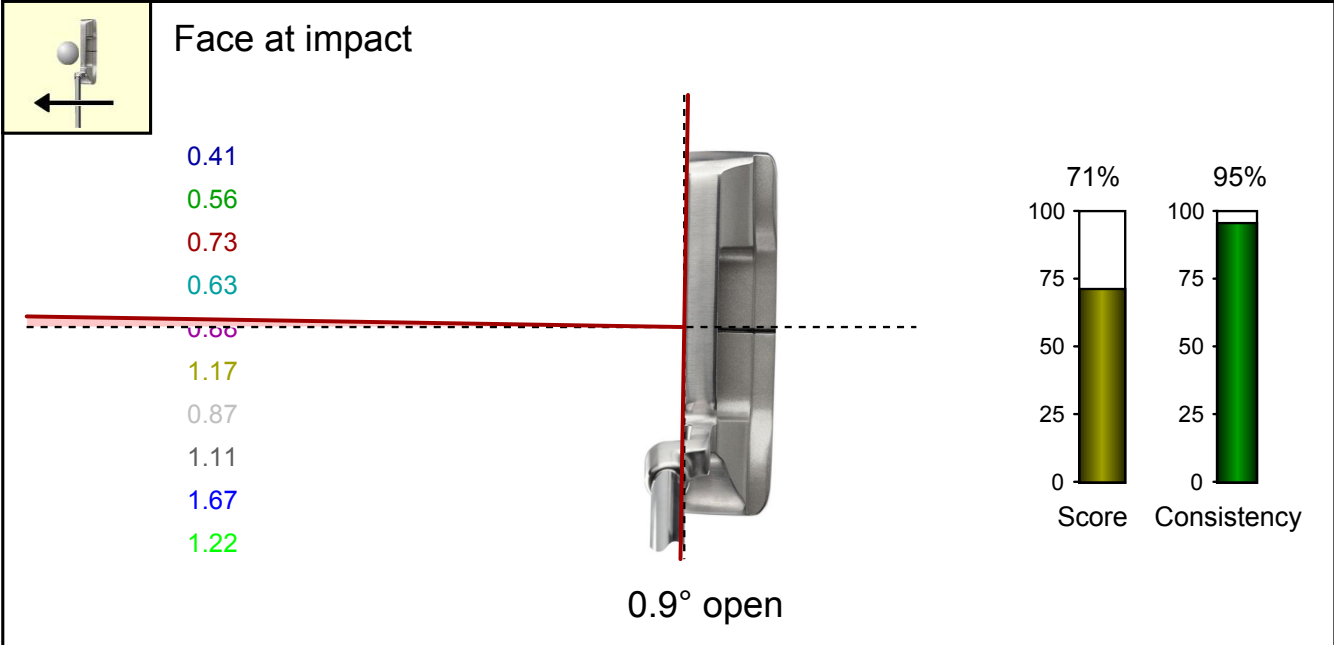

Project: SPELARE
 Player: Gornik, Tim
 File: Extended Measurement
 Date: 02.07.2014

Path & Spot

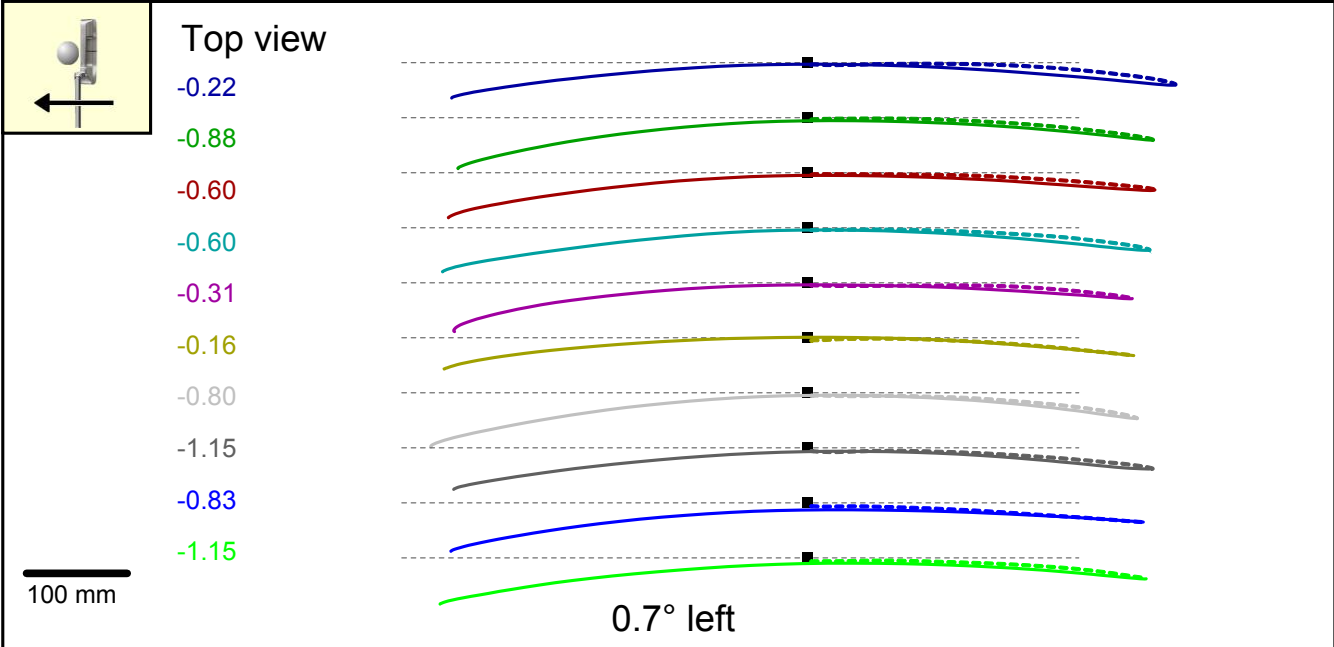

Impact spot



Spot: 1.2 mm toe

Lie angle: 2.4 ° toe up

Backswing Ratio

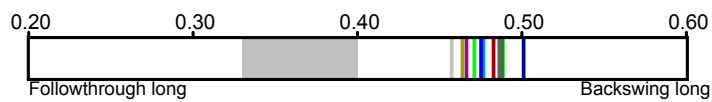

0.48

Impact spot

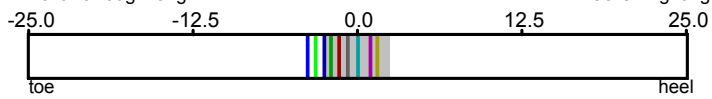

1.2 mm toe

Height on Face

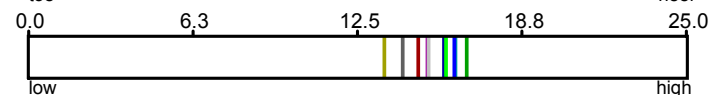

15.4 mm

Project: SPELARE
 Player: Gornik, Tim
 File: Extended Measurement
 Date: 02.07.2014

Loft & Rise

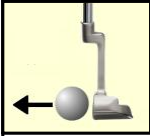

Side view

- 1.99
- 2.17
- 1.78
- 1.92
- 2.19
- 2.17
- 1.45
- 1.62
- 2.26
- 2.12

100 mm

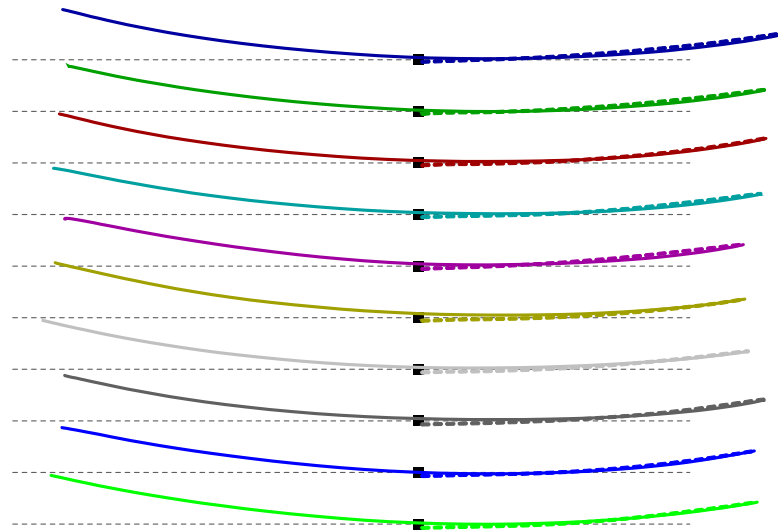

Rise at impact: 2.0° up

Launch & Spin

Shaft angle: 1.7° deloft
 (Putter Loft: 3.0°)
 Eff. Loft: 1.3° positive

Pred. launch: 1.4° up

Rise angle: 2.0° up

Predicted Spin: top

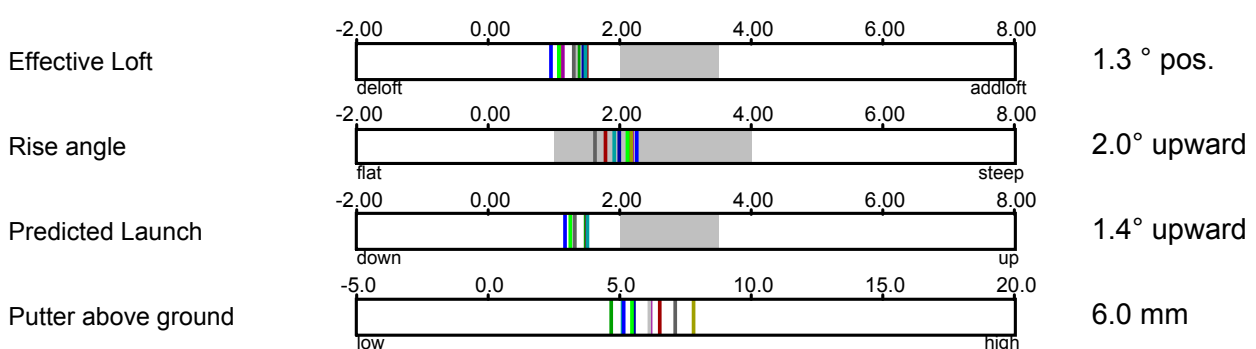
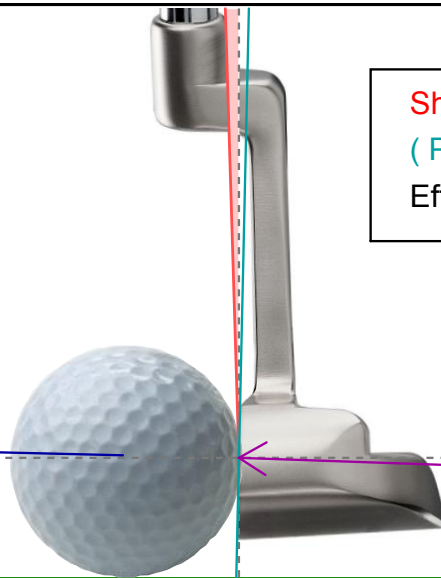

Project: SPELARE
Player: Gornik, Tim
File: Extended Measurement
Date: 02.07.2014

Face Rotation

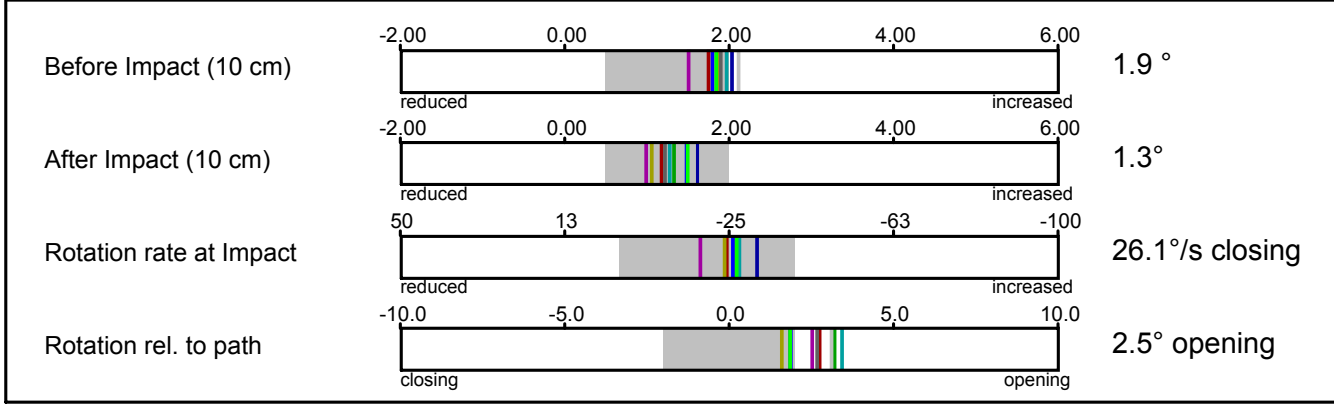
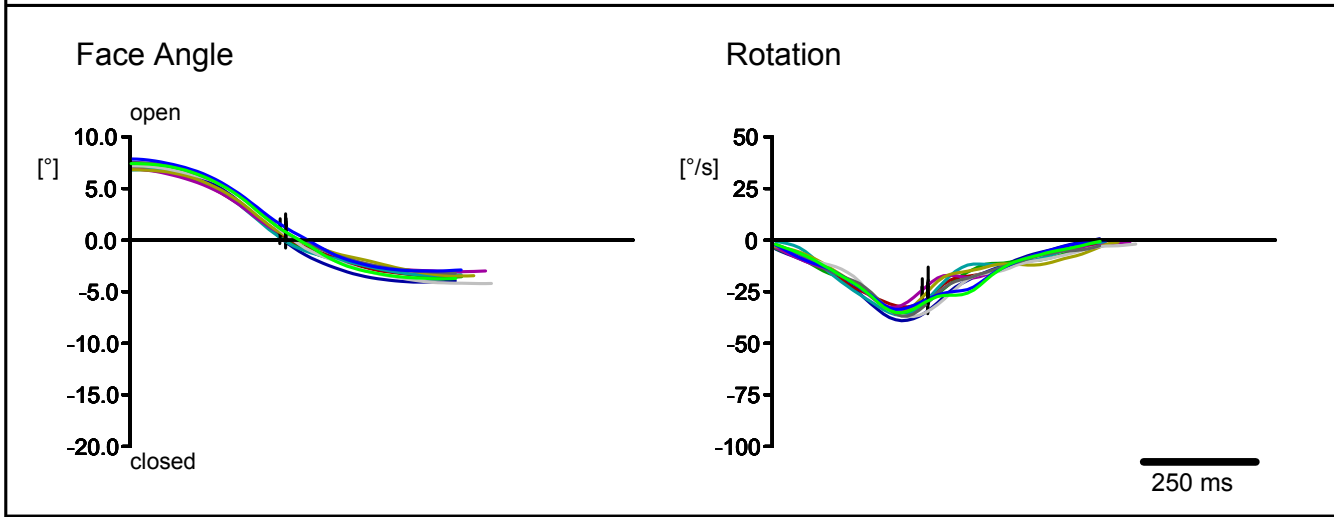
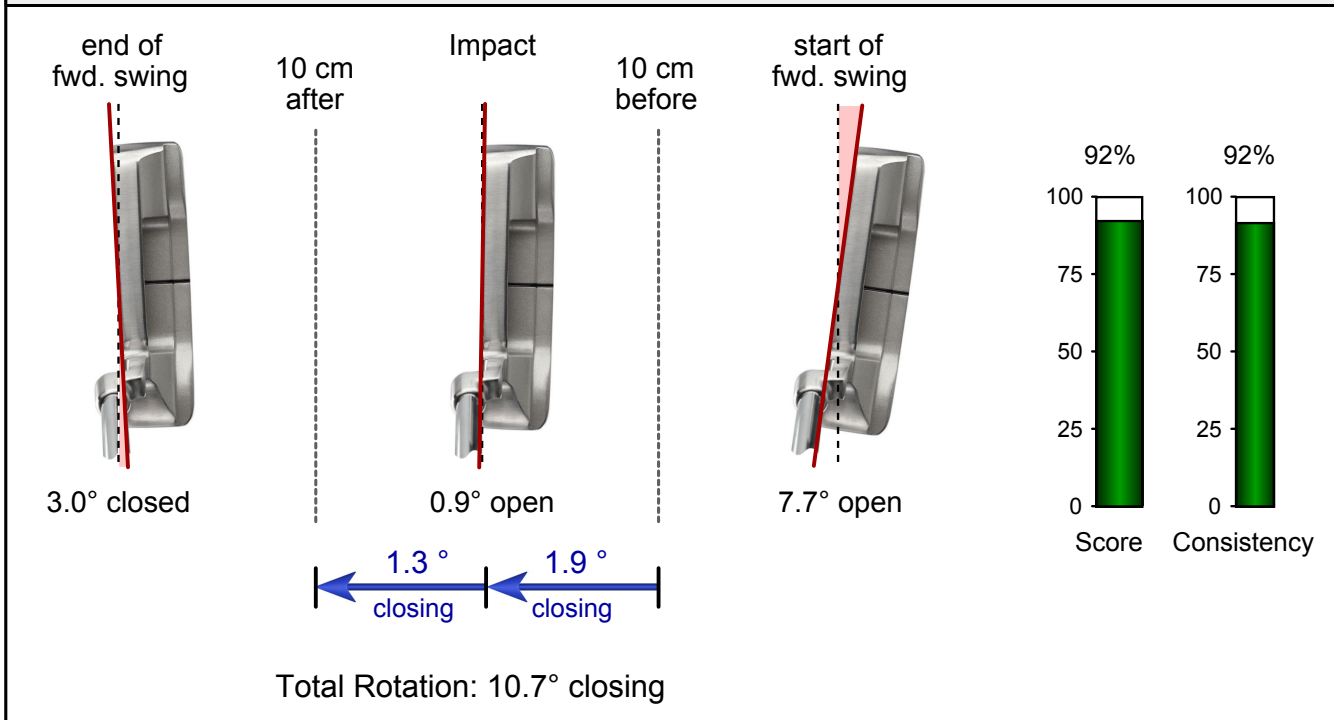

Project: SPELARE
 Player: Gornik, Tim
 File: Extended Measurement
 Date: 02.07.2014

Movement Dynamics

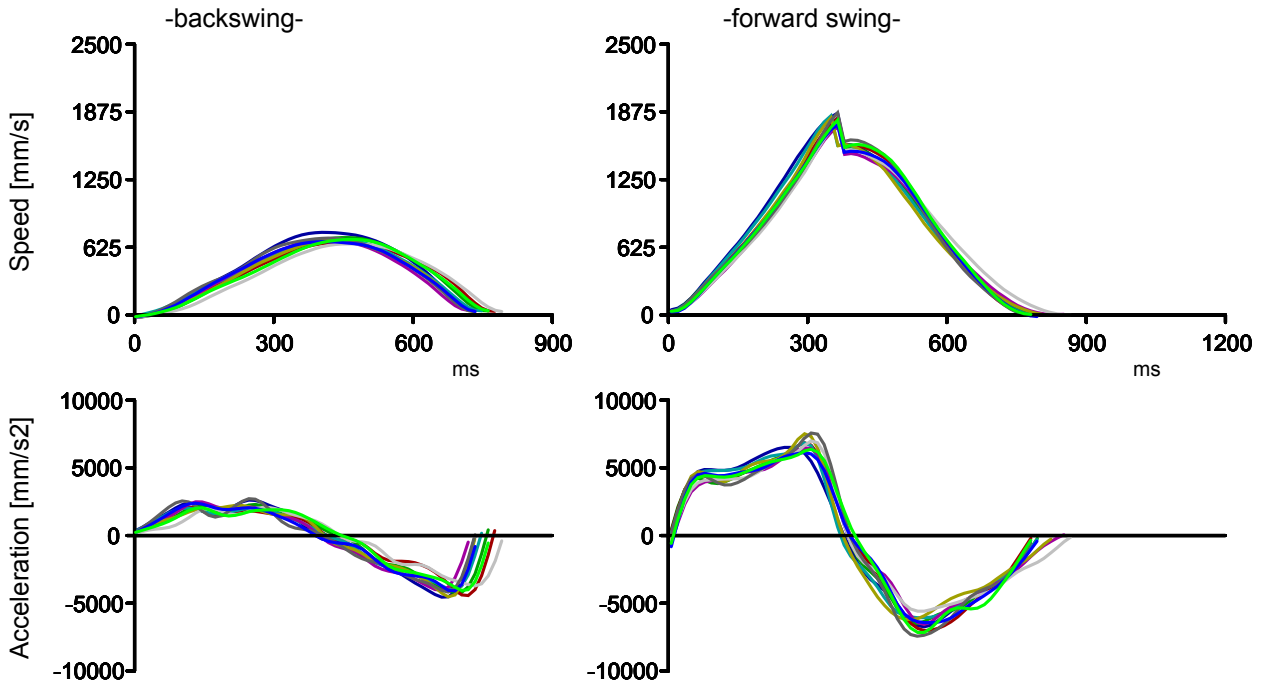

Timing

